

**LEADING IN
PRODUCTION
EFFICIENCY**



EcoGun 116

Manual Air Spray Gun Gravity-Feed

Operation manual

MSG00017EN, V04

N36200006V

Information about the document

This document describes the correct handling of the product.

- Read the document prior to every activity.
- Prepare the document for the application.
- Pass on the product only together with the complete documentation.
- Always follow safety instructions, handling instructions and specifications of every kind.
- Illustrations can deviate from the technical construction.

Validity range of the document

This document describes the following products:

N36200006V
EcoGun 116



Hotline and Contact

If you have queries or would like technical information, please contact your dealer or sales partner.

TABLE OF CONTENTS

1	Product overview	4	8	Maintenance	19
	1.1 Overview.....	4		8.1 Safety recommendations.....	19
	1.2 Short description.....	4		8.2 Maintenance schedule.....	21
2	Safety	4	9	Faults	22
	2.1 Presentation of Notes.....	4		9.1 Safety recommendations	22
	2.2 Intended Use.....	5		9.2 Defects table.....	23
	2.3 Residual risks.....	5		9.3 Troubleshooting.....	25
	2.4 Staff qualification.....	6		9.3.1 Replace needle and nozzle.....	25
	2.5 Personal protective equip- ment.....	7		9.3.2 Replace valve set.....	27
3	Transport, scope of supply and storage	7	10	Disassembly and Disposal	31
	3.1 Scope of delivery.....	7		10.1 Safety recommendations....	31
	3.2 Handling of packaging material.....	7		10.2 Disassembly.....	32
	3.3 Storage.....	8		10.3 Disposal	32
4	Assembly	8	11	Technical data	32
	4.1 Requirements for the Installation point.....	8		11.1 Weight.....	32
	4.2 Assembly.....	8		11.2 Connections.....	32
5	Commissioning	9		11.3 Operating conditions.....	32
6	Operation	11		11.4 Emissions.....	32
	6.1 Safety recommendations.....	11		11.5 Operating values.....	33
	6.2 General notes.....	11		11.6 Type plate.....	33
	6.3 Selecting air cap.....	11		11.7 Materials used.....	33
	6.4 Changing the air cap.....	12		11.8 Operating and auxiliary materials.....	33
	6.5 Alignment of the air cap.....	12		11.9 Material specification.....	33
	6.6 Guiding the spray gun.....	13	12	Spare parts, tools and accesso- ries	34
	6.7 Purging.....	13		12.1 Spare parts.....	34
	6.7.1 Safety recommendations...	13		12.2 Tools.....	39
	6.7.2 General notes.....	13		12.3 Accessories.....	40
	6.7.3 Purging spray gun.....	14		12.4 Order.....	47
7	Cleaning	15			
	7.1 Safety recommendations.....	15			
	7.2 Cleaning.....	17			

1 Product overview

1.1 Overview

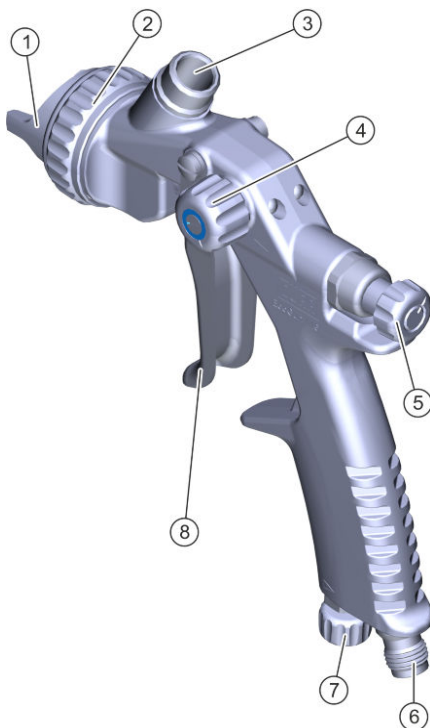

Fig. 1: Overview

- 1 Air cap
- 2 Cap nut
- 3 Material connection for flow cups
- 4 Flat jet control
- 5 Material flow control
- 6 Air connection
- 7 Air control
- 8 Trigger

1.2 Short description

The spray gun is intended for surface coating. Compressed air is used to apply material. The material to be atomized is fed via flow cups. The spray gun is handheld.

Use a suitable nozzle set with air cap, depending on the requirement ↪ 6.3 "Selecting air cap".

The following factors influence the spray jet and the result:

- Alignment of the air cap ↪ 6.5 "Alignment of the air cap"
- Material flow ↪ 5 "Commissioning"
- Air pressure ↪ 5 "Commissioning"
- Horn air pressure ↪ 5 "Commissioning"

The spray gun uses a self-adjusting needle package. The needle gland automatically adjusts for the material-related wear of the needle gland. In addition, the needle packing can be readjusted mechanically.

2 Safety

2.1 Presentation of Notes

The following notes can appear in this instruction:

DANGER!

High risk situation that can lead to serious injuries or death.

WARNING!

Medium risk situation that can lead to serious injuries or death.

CAUTION!

Low risk situations that can lead to minor injuries.

! NOTICE!

Situations that can lead to material damage.



ENVIRONMENT!

Situations that can lead to environmental damage.



Additional information and recommendations.

2.2 Intended Use

The spray gun **EcoGun 116** is used exclusively for hand guided spraying coating of surfaces. Compressed air is used to apply material.

The material feed is gravity-fed (feed cups). The use is only permitted in the industrial area within the specified technical data. ↪ 11 “Technical data”

The spray gun is approved for use in explosive areas of Ex zones 1 and 2.

Misuse

There is a risk of death if not used properly. Misuses include, e. g.:

- Aiming the spray gun at humans or animals.
- Atomization of fluid nitrogen
- Combination of the spray gun with components that are not approved by Dürr Systems for operation.
- Use of unapproved materials, see safety data sheets
- Making conversions or changes on your own
- Use of spray gun in Ex zone 0

EX labeling

 II 2G T60°C X

- II - Device group II: all areas except mining
- 2G - Device category 2 for gas
- T60 °C - Surface temperature max. 60 °C
- X - Specific operating conditions for safe operation

The following conditions must be observed for safe operation:

- Ground spray gun and work piece.
- Only use conductive air hoses.
- Ensure that static electricity can be discharged.
- Use exclusively compressed air quick couplings for water-based materials, where it is not necessary to keep discharging static electrical charges.

2.3 Residual risks

Explosion

Sparks, open flames and hot surfaces can cause explosions in explosive atmospheres. Serious injury and death could be the consequence.

- Before carrying out any work, make sure that there is no explosive atmosphere.
- Do not use sources of ignition and open light.
- Do not smoke.
- Ground the spray gun.
- Ground the work piece.
- Only use conductive lines.

Flammable coating materials and their detergents and cleaning agents can cause a fire or an explosion.

- Ensure that the flashpoint of the cleaning agent is at least 15K above the ambient temperature or clean Product at the cleaning areas with active technical ventilation, in painting booths, according to EN 16985.
- Note explosion group of the fluid.
- Follow the safety data sheet.
- Ensure that forced ventilation and fire protection equipment are in operation.
- Do not use sources of ignition and open light.
- Do not smoke.
- Ground the spray gun.

Danger from harmful or irritant substances

Serious injuries or death can result if you come into contact with dangerous fluids or steam.

- Product Check regularly for leakage. Observe local regulations and maintenance schedule.
- Ensure that the forced ventilation is operational.
- Follow the relevant safety data sheets.
- Wear specified protective equipment.

Escaping material

Material escaping under pressure can cause serious injuries.

Before working on the product:

- Disconnect the system, in which the product is installed, from compressed air and material supply.
- Secure system personalized from being switched on again.
- Depressurize the lines.

Noise

The sound pressure level during operation may cause severe hearing damage.

- Wear ear protection.
- Do not spend more time than necessary in the work area.

Hot surfaces

During operation, the surfaces of components can get extremely hot. Contact with it can cause burns.

- Do not touch hot surfaces.
- Before carrying out any work:
 - Let components cool down.
 - Wear protective hand gloves.

2.4 Staff qualification



WARNING!

Inadequate qualification

Wrong estimation of dangers can cause serious injury or death.

- Only sufficiently qualified persons may execute all work.
- Some work requires additional qualification. Additional qualifications of specialized personnel are marked with a "+".

This document is intended for qualified personnel in industry and craftsmanship.

The following describes the different qualifications required for the work in this document. The required qualification is presented prior to the individual tasks in the appropriate chapters.

Operator

The operator is trained specifically for the field of work in which he works.

Furthermore, the operator possesses the following knowledge:

- Technical Measures for occupational safety and health

Transport, scope of supply and storage

The operator is responsible for the following work:

- Operate and monitor the system/ product.
- Introduce measures in the event of faults.
- Clean system/ product.

+ additional qualification explosion protection

In addition to the knowledge of the various specialist fields, the mechanic has knowledge of regulations and safety measures when working in potentially explosive areas.

Dürr Systems offers special product training for ↪ "Hotline and Contact".

2.5 Personal protective equipment

When working in explosive areas, the protective clothing, including gloves, must meet the requirements of EN 1149-5. Footwear must meet the requirements of ISO 20344 and IEC 61340-4-3. The volume resistivity must not exceed 100MΩ.

Wear the specified personal protective equipment when working. Provide the following personal protective equipment:



Eye protection

Protects eyes from dust, paint drops and particles.



Protective gloves

Protect the hands from:

- mechanical forces
- Thermal forces
- Chemical effects



Protective workwear

Tight fitting workwear with low tear strength, tight sleeves and no hanging parts.



Respiratory protection device

The respiratory protection device protects from hazardous gases, vapors, dust and similar materials and media. The version of the respiratory protection device must be suitable for the media used as well as their usage.



Safety boots

Protect feet from crushing, falling items and slipping.



Use ear protection

Protects from auditory damage due to noise.

3 Transport, scope of supply and storage

3.1 Scope of delivery

The scope of supply includes the following components:

- Spray gun
- Tool kit ↪ 12.2 "Tools"

Inspect delivery on receipt for completeness and integrity.

Report defects immediately ↪ "Hotline and Contact".

3.2 Handling of packaging material



ENVIRONMENT!

Incorrect disposal

Incorrectly disposed packaging material can damage environment.

- Dispose of material no longer required in an environment-friendly manner.
- Observe local disposal specifications.

3.3 Storage

Storage provisions:

- Do not store outdoors.
- Product only store when in a clean and dry condition.
- Store in a dust-free place.
- Do not expose to aggressive media.
- Protect from solar radiation.
- Avoid mechanical vibrations.
- Temperature: 10°C to 40°C
- Relative humidity: 35% to 90%

4 Assembly

4.1 Requirements for the Installation point

- The compressed air supply to the spray gun must be interrupted and secured against reconnection.
- The compressed air supply must be adjustable.
- Lines, seals and screw connections must be designed to conform to the requirements of the spray gun ↗ 11 "Technical data".
- The workplace must have a mechanical ventilation.

Working environment and grounding

The flooring of the working area must be anti-static acc. to EN 50050-1, measurement after EN 1081. The antistatic flooring prevents electrostatic charges from building up. Dangerous flashovers are prevented.

4.2 Assembly

Personnel:

- Operator
- + additional qualification explosion protection

Protective equipment:

- Protective workwear

- Protective gloves

1.  **WARNING!**
Sources of ignition may cause explosions!
Ensure a non-explosive atmosphere.

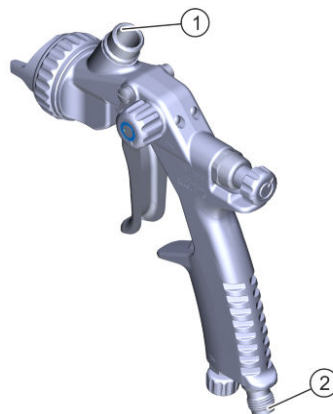

Fig. 2: Assembling

2. Screw the feed cup onto the thread of the material connection (1).
3. Connect air hose to the air connecting (2).
4. Check air hose for correct seating.

5 Commissioning

Personnel:

- Operator
- + additional qualification explosion protection

Protective equipment:

- Protective gloves
- Safety boots
- Protective workwear
- Eye protection
- Respiratory protection device
- Use ear protection

Requirements:

- Feed cup and air hose have been connected ↪ 4.2 "Assembly".

1. Rinse the spray gun before filling it with paint ↪ 6.7 "Purging":
 - For easily flammable coating materials with solvent
 - For not easily flammable coating materials with water
2. Create a trial spray pattern on a test work piece.

Setting the material flow

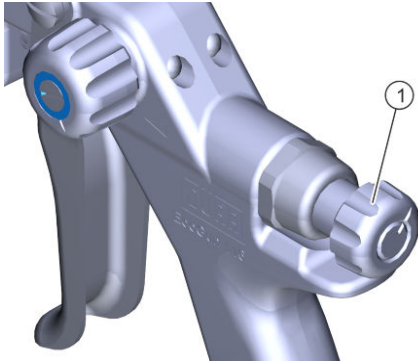

Fig. 3: Setting the material flow

1. Set the material quantity.
 - Turn material amount control (1) in desired direction.
 - Right turn: less material
 - Left turn: more material

i Turn material amount control to the right but not up to the mechanical stop. The needle can then no longer move properly. For reduction of the material quantity, it is preferable to use a smaller nozzle set and not the material quantity control. To increase the material quantity, preferably use a larger nozzle set.

Set total air pressure

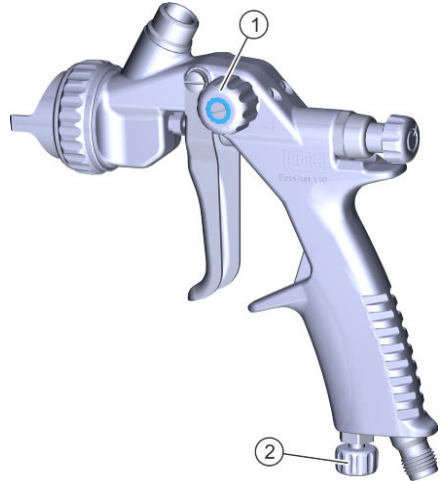

Fig. 4: Set total air and horn air pressure

2. Set the total air pressure by turning the total air control (2).
 - Right turn: Lower total air pressure
 - Left turn: higher total air pressure

i Observe the following characteristic curve.

Set horn air pressure

3. Set horn air pressure by turning the flat jet control (1).
 - Right turn: rounder jet pattern
 - Left turn: flatter jet pattern

i You can turn the flat jet control continuously and adjust the spray pattern from flat to round jet.

Characteristic curves

The characteristic curves show the air flow rate for various nozzle sets and air caps for different air pressures.

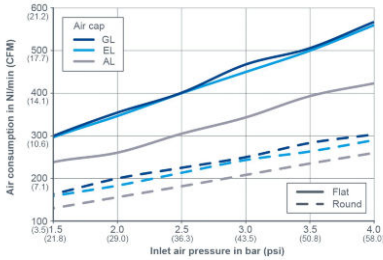

Fig. 5: Characteristic curve

GL Nozzle set with air cap GL
 EL Nozzle set with air cap EL
 AL Nozzle set with air cap AL
 X-Achse Atomizer air pressure and control air pressure [bar (psi)]
 Y-Achse Flow rate [Nl/min (CFM)]

6 Operation

6.1 Safety recommendations



Danger of explosion due to chemical reactions

Material, halogenated hydrocarbon-based rinsing agent or cleaning agent can chemically react with aluminum components of the product. Chemical reactions can cause explosions. Serious injury and death could be the consequence.

- Only use purging agents and cleaning agents that do not contain any halogenated hydrocarbons.

! NOTICE!

Material damage due to dried material residues

If material residues dry in the product, that can harm components.

- Purge product immediately after each use.

6.2 General notes

- Perform the following checks during operation:
 - Check O-rings for correct seating and tightness.
 - Check air car for cleanliness.
 - Check nozzle for cleanliness.

6.3 Selecting air cap

You can convert the spray gun for various uses by swapping the air cap.

Air cap AL

The air cap AL is used for flammable coating materials (1-component paints and 2-component paints) and non-flammable coating materials. It is used for application of fillers, base coats and topcoats. If used with a hardened nozzle, coating materials with abrasive additives (coating materials containing zinc and aluminum) can be applied.

Air cap EL

If higher flow rates are necessary, the air cap EL is used for flammable coating materials (1-component paints and 2-component paints) and non-flammable coating materials.

Air cap GL

The air cap GL is used for thick flowing, high viscosity coating materials with high outflow rates.

6.4 Changing the air cap

Personnel:

- Operator
- + additional qualification explosion protection

Protective equipment:

- Protective workwear
- Protective gloves

Removing the air cap

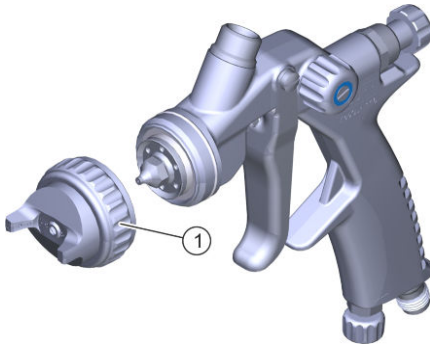

Fig. 6: Removing the air cap

1. Loosen cap nut (1).
2. Remove the air cap (1).

Assembling air cap

3. Place the air cap (1).
4. Align the air cap as required ↪ 6.5 "Alignment of the air cap".
5. Tighten cap nut (1).

6.5 Alignment of the air cap

Personnel:

- Operator
- + additional qualification explosion protection

Protective equipment:

- Protective workwear
- Protective gloves

The position of the air cap determines the alignment of the spray pattern.

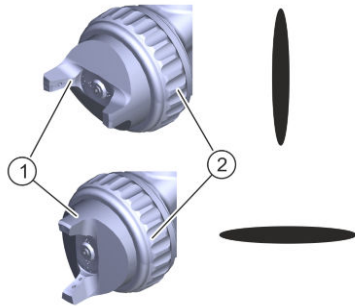

Fig. 7: Air cap alignment

1. Lightly loosen cap nut (2).
2. Turn the air cap (1) as required for the desired spray pattern.
3. Tighten cap nut (2) by hand.

6.6 Guiding the spray gun

Personnel:

- Operator
- + additional qualification explosion protection

Protective equipment:

- Protective gloves
- Safety boots
- Protective workwear
- Eye protection
- Respiratory protection device
- Use ear protection

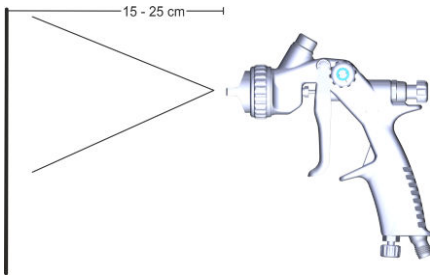

Fig. 8: Guiding the paint gun

1. Guide the spray gun as follows:

- Guide spray gun at 90 degrees to the surface.
- Maintain a distance of 15 to max. 25 cm to the surface.



The distance can vary for effect coatings.

6.7 Purging

6.7.1 Safety recommendations

! NOTICE!

Material damage due to unsuitable rinsing agent

If the rinsing agent reacts chemically with the components or the material, components get damaged.

- Use only the rinsing agents that are compatible with the components and the material.
- Refer to safety data sheet of material manufacturer.

6.7.2 General notes

When purging, use fluid to remove inner soiling from components.

6.7.3 Purging spray gun

Personnel:

- Operator
- + additional qualification explosion protection

Protective equipment:

- Use ear protection
- Eye protection
- Respiratory protection device
- Protective workwear
- Protective gloves

Purging spray gun:

- After end of work
- Before every change of material
- Prior to cleaning
- Prior to dismantling
- Before a long time of non-use
- Before placing in storage



Additional purging intervals depend on the material used.

Preparation for purging

1. Disconnect the air hose from the spray gun.

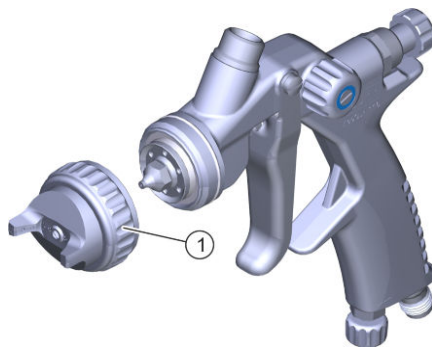

Fig. 9: Removing the air cap

2. Loosen cap nut (1).
3. Remove the air cap (1).

Purging

4. Keep collecting tray ready.

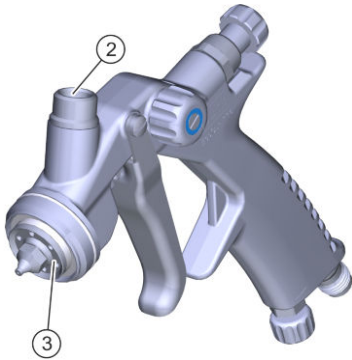

Fig. 10: Purging spray gun

5. Keep the spray gun slightly at an angle above the collecting tray, nozzle (3) pointing towards the ground.
6. Purge the spray gun with an appropriate rinsing agent through the material connection (2), until the rinsing agent runs clean without any material residue. Use a brush to carefully clean the holes (3) of the nozzle.
7. Ensure proper disposal of the exiting material and rinsing agent.
8. Connect the compressed air hose to the spray gun.
9. Operate trigger lever until no more rinsing agent flows out.

Final work

10. Place the air cap (1).
11. Tighten cap nut (1).

7 Cleaning

7.1 Safety recommendations



WARNING!

Danger of fire and explosion

Flammable coating materials and their detergents and cleaning agents can cause a fire or an explosion.

- Ensure that the flashpoint of the cleaning agent is at least 15K above the ambient temperature or clean product at the cleaning areas with active technical ventilation, in painting booths, according to EN 16985.
- Note explosion group of the fluid.
- Observe the security data sheets of the media being used.
- Ensure that forced ventilation and fire protection equipment are in operation.
- Do not use sources of ignition and open light.
- Do not smoke.
- Check grounding.



WARNING!

Unsuitable spare parts in explosive areas

Spare parts not compliant with the specifications on explosion protection can cause explosions in an explosive atmosphere. Serious injury and death could be the consequence.

- Use exclusively original spare parts.

**WARNING!****Danger from harmful or irritant substances**

Serious injuries or death can result if you come into contact with dangerous fluids or steam.

- Product Check regularly for leakage. Observe local regulations and maintenance schedule.
- Ensure that the forced ventilation is operational.
- Follow the relevant safety data sheets.
- Wear specified protective equipment.
- Avoid contact (e.g. with eyes, skin).

**WARNING!****Escaping material and compressed air**

Escaping material under pressure can cause serious injuries.

Before carrying out any work:

- Disconnect the system, in which the spray gun is installed, from compressed air and material supply.
- Secure system personalized from being switched on again.
- Depressurize the lines.

**WARNING!****Danger of explosion due to chemical reactions**

Material, halogenated hydrocarbon-based rinsing agent or cleaning agent can chemically react with aluminum components of the product. Chemical reactions can cause explosions. Serious injury and death could be the consequence.

- Only use purging agents and cleaning agents that do not contain any halogenated hydrocarbons.

**CAUTION!****Risk of injury due to spring tension**

The set screw of the spray gun is under spring tension. If you remove the set screw, the spring tension could cause the set screw to jump out unexpectedly and cause light injuries.

- Remove and install set screw.

! NOTICE!

Unsuitable cleaning agents

Unsuitable cleaning agents can damage the spray gun.

- Only use cleaning agents approved by the material manufacturer.
- Observe the security data sheets of the media being used.
- Place heavily soiled components in a cleaning bath.
 - Only place those parts in the cleaning bath, which are suitable for the cleaning bath.
Never place the entire spray gun in the cleaning bath.
 - Use only electrically conductive containers.
 - Ground the container.
 - Do not use ultrasound baths.

- Use alcohols (isopropanol, butanol) for non-flammable coating materials.
- Remove dried non-flammable coating materials using a material manufacturer-approved organic thinner.
- When cleaning with flammable detergent, do not spray into a closed container. An explosive gas-air mixture can form inside closed containers.

! NOTICE!

Damage due to unsuitable cleaning tools

Unsuitable cleaning tools can damage the product.

- Only use cloths, soft brushes and paintbrushes.
- Do not use abrasive cleaning tools.
- Do not poke blocked nozzles with metallic objects.
- Do not use compressed air for cleaning.
- Do not use any thinner spray guns.
- Do not use high pressure for cleaning agents.

7.2 Cleaning

Personnel:

- Operator
- + additional qualification explosion protection

Protective equipment:

- Use ear protection
- Eye protection
- Respiratory protection device
- Protective workwear
- Protective gloves

1. Purge spray gun ↪ 6.7 “Purging”.
2. Disconnect the air hose from the spray gun.
3. Remove feed cup.
4. Remove material residues with a cloth or a soft brush.
5. Clean the spray gun carefully and dry it with a soft cloth.

Clean filter of the flow cup.

Personnel:

- Operator
- + additional qualification explosion protection

Protective equipment:

- Protective workwear
- Protective gloves

Depending on the configuration, the spray gun is supplied with a filter.

For a thorough cleaning, you can remove the filter.

Disassembly



Fig. 11: Clean filter.

1. Pull out filter (1) on the holding pin from the material connector.
2. Clean the filter (1) in the cleaning bath.
3. Insert filter (1) in the material connector and push down until it sits firmly.

Cleaning the air cap und nozzle

Personnel:

- Operator
- + additional qualification explosion protection

Protective equipment:

- Protective workwear
- Protective gloves

For a thorough cleaning you can remove the air cap and the nozzle.

Disassembly

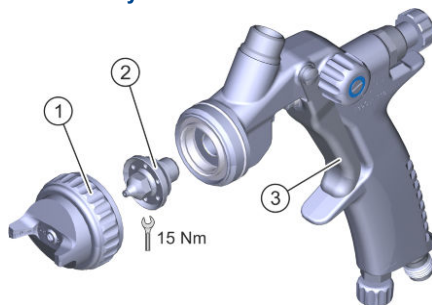



Fig. 12: Disassemble air cap and nozzle

1. Loosen cap nut (1).
2. Remove air cap (1).
3. Push trigger lever (3) through. Keep it pressed.
⇒ The needle is pushed backwards so that it will not be damaged during disassembly of the nozzle.
4. Unscrew and remove nozzle (2) using monkey wrench.
5. Release the trigger lever (3).

6. Clean air cap (1) using cleaning agent and cleaning brush  12.2 "Tools".
7. Wipe the cleaned air cap dry with a cloth.
8. Clean nozzle (2) in the cleaning bath.
9. Clean nozzle seat with a cloth or a soft brush.

Assembly

10. Push trigger lever (3) through. Keep it pressed.
 - ⇒ he needle is pushed backwards so that it will not be damaged during assembly of the nozzle.
11. Insert and tighten nozzle (2).
Tightening torque: 15Nm
12. Release the trigger lever (3).
13. Fit air cap (1).
14. Tighten cap nut (1).

8 Maintenance

8.1 Safety recommendations



WARNING!

Danger of fire and explosion

Flammable coating materials and their detergents and cleaning agents can cause a fire or an explosion.

- Ensure that the flashpoint of the cleaning agent is at least 15K above the ambient temperature or clean product at the cleaning areas with active technical ventilation, in painting booths, according to EN 16985.
- Note explosion group of the fluid.
- Observe the security data sheets of the media being used.
- Ensure that forced ventilation and fire protection equipment are in operation.
- Do not use sources of ignition and open light.
- Do not smoke.
- Check grounding.



WARNING!

Unsuitable spare parts in explosive areas

Spare parts not compliant with the specifications on explosion protection can cause explosions in an explosive atmosphere. Serious injury and death could be the consequence.

- Use exclusively original spare parts.

**WARNING!****Danger from harmful or irritant substances**

Serious injuries or death can result if you come into contact with dangerous fluids or steam.

- Product Check regularly for leakage. Observe local regulations and maintenance schedule.
- Ensure that the forced ventilation is operational.
- Follow the relevant safety data sheets.
- Wear specified protective equipment.
- Avoid contact (e.g. with eyes, skin).

**WARNING!****Escaping material and compressed air**

Escaping material under pressure can cause serious injuries.

Before carrying out any work:

- Disconnect the system, in which the spray gun is installed, from compressed air and material supply.
- Secure system personalized from being switched on again.
- Depressurize the lines.

**WARNING!****Danger of explosion due to chemical reactions**

Material, halogenated hydrocarbon-based rinsing agent or cleaning agent can chemically react with aluminum components of the product. Chemical reactions can cause explosions. Serious injury and death could be the consequence.

- Only use purging agents and cleaning agents that do not contain any halogenated hydrocarbons.

**CAUTION!****Risk of injury due to spring tension**

The set screw of the spray gun is under spring tension. If you remove the set screw, the spring tension could cause the set screw to jump out unexpectedly and cause light injuries.

- Remove and install set screw.

! NOTICE!

Unsuitable cleaning agents

Unsuitable cleaning agents can damage the spray gun.

- Only use cleaning agents approved by the material manufacturer.
- Observe the security data sheets of the media being used.
- Place heavily soiled components in a cleaning bath.
 - Only place those parts in the cleaning bath, which are suitable for the cleaning bath.
Never place the entire spray gun in the cleaning bath.
 - Use only electrically conductive containers.
 - Ground the container.
 - Do not use ultrasound baths.

! NOTICE!

Damage due to unsuitable cleaning tools

Unsuitable cleaning tools can damage the product.

- Only use cloths, soft brushes and paintbrushes.
- Do not use abrasive cleaning tools.
- Do not poke blocked nozzles with metallic objects.
- Do not use compressed air for cleaning.
- Do not use any thinner spray guns.
- Do not use high pressure for cleaning agents.

- Use alcohols (isopropanol, butanol) for non-flammable coating materials.
- Remove dried non-flammable coating materials using a material manufacturer-approved organic thinner.
- When cleaning with flammable detergent, do not spray into a closed container. An explosive gas-air mixture can form inside closed containers.

8.2 Maintenance schedule

The maintenance intervals given below are based on experiential values. Adjust maintenance intervals individually with increased requirements.

Interval	Maintenance work
After each use	Clean ↪ 7 “Cleaning”.
Daily	Check state and tightness of the spray gun as well as of the connections and lines.
Weekly	Lubricate lever bearing ↪ 8.3 “Lubrication”.

8.3 Lubrication

The following components must be lubricated with a silicone-free grease:

- O-rings and seals
- Bearing
- Set screw and threads
- Needle gland
- Lever bearing



Lubricate internal components at the time of maintenance work, which include disassembly of the concerned components any way.

Recommended lubricant: SYN-THESO GLEP 1 ↗ 11.8 "Operating and auxiliary materials"

NOTICE!

Property damage due to improper handling

Mechanical load can damage needle and nozzle.

- Handle with care during installation and dismantling.
- Do not subject the needle to any mechanical pressure.
- Avoid collisions of components to be assembled and disassembled with the needle.
- Do not excessively tighten components.

9 Faults

9.1 Safety recommendations







NOTICE!

Property damage due to improper replacement of needle and nozzle

Replacing only the needle or only the nozzle could damage spray gun components. This can compromise the tightness of the spray gun. The spray pattern deteriorates.

- Observe order of replacement steps (needle – nozzle).
- Observe order of assembly steps (nozzle – needle).
- Always replace nozzle and needle at the same time.

9.2 Defects table

Visualizer of typical spray pattern problems	
Spray pattern	Fault identification
	Spray jet is distorted.
	Spray jet is bent or tapered.
	Spray jet is too thick in the middle.
	Spray jet is split.
	Spray jet is uneven.

Fault description	Cause	Remedy
No material	Feed cup empty	Check feed cup. Top up, if necessary.
	Air pressure too high (only when using an extension)	Decrease the air pressure via the total air control.
Material escapes at the needle gland.	Needle gland worn out	Replace needle gland ↻ 9.3.3 "Replace needle gland".
	Needle gland loose	Tighten needle gland sensitively.
Air escapes between valve pin and housing.	Valve seal worn out	Replace valve seal ↻ 9.3.2 "Replace valve set".

Fault description	Cause	Remedy
Spray gun is losing air with non-actuated trigger.	Valve pin or valve seat is defective or worn.	Replace the valve pin or valve seat ↪ 9.3.2 "Replace valve set".
Spray jet is distorted.	Air cap is misaligned	Rotate air cap into the required position ↪ 6.5 "Alignment of the air cap".
Spray jet is bent or tapered.	Bores in air cap are soiled	Clean and check air cap. Replace air cap if defective ↪ 7 "Cleaning".
	Nozzle soiled or defective	Clean and check the nozzle. If nozzle is defective, replace it along with the needle ↪ 9.3.1 "Replace needle and nozzle..".
Spray jet is too thick in the middle.	Material too viscous	Change material consistency.
	Horn air pressure too low	Decrease the horn air pressure via the flat jet control.
	Air pressure too low	Increase the air pressure via the total air control.
Spray jet is split.	Material too thin	Change material consistency.
	Horn air pressure too high	Decrease the horn air pressure via the flat jet control.
	Air pressure too high	Decrease the air pressure via the total air control.
Spray jet is uneven. The spray pattern quality is bad.	Not enough material in the cup	Top up material.
	Cap nut or nozzle is not properly tightened	Tighten cap nut and nozzle ↪ "Cleaning the air cap und nozzle".
	Needle gland worn out	Replace needle gland ↪ 9.3.3 "Replace needle gland".

9.3 Troubleshooting

9.3.1 Replace needle and nozzle.



The disassembly and assembly of the needle for the common gun versions are described in the “Standard version” section.

The version of the spray gun with GL air cap and 4.0 mm nozzle is disassembled and assembled in a different manner. Follow the relevant section.

Standard version

Personnel:

- Operator
- + additional qualification explosion protection

Protective equipment:

- Protective workwear
- Protective gloves

Disassembly

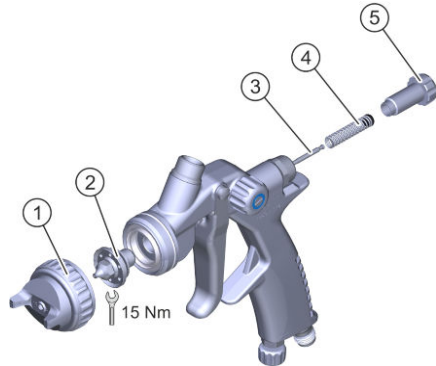

Fig. 13: Disassemble needle and nozzle (standard version)

1. Unscrew and remove set screw (5).
2. Push trigger lever through.
⇒ The needle (3) is pushed a little backwards out of the housing.
3. Remove bearing and needle spring (4).
4. Remove (3) needle.
5. Loosen cap nut (1).
6. Remove air cap (1).
7. Unscrew and remove nozzle (2) using monkey wrench.
8. Replace worn out or defective components.

Assembly

9. Insert and tighten nozzle (2).
Tightening torque: 15Nm
10. Fit air cap (1).

11. Tighten cap nut (1).
12. Push needle (3) carefully into the housing.
13. Push needle spring and bearing (4) onto the needle.
14. Set and thread-in set screw (5).

Version with GL air cap and 4.0 mm nozzle

Personnel:

- Operator
- + additional qualification explosion protection

Protective equipment:

- Protective workwear
- Protective gloves

Disassembly

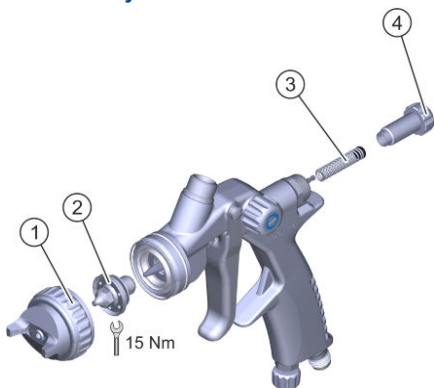

Fig. 14: Disassemble needle and nozzle

1. Unscrew and remove set screw (4).
2. Remove bearing and needle spring (3).

3. Loosen cap nut (1).
4. Remove air cap (1).
5. Unscrew nozzle (2) and remove using monkey wrench.

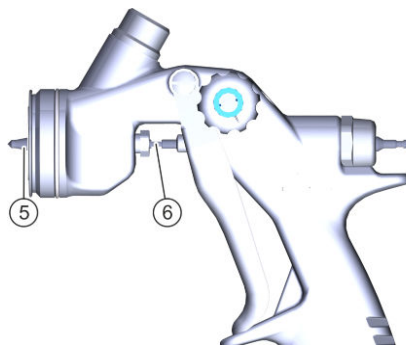

Fig. 15: Disassemble needle

6. Secure needle (6) on the wrench mount in the center of the spray gun with the monkey wrench before twisting.
7. Loosen the needle tip (5) using an installation wrench.
8. Push trigger lever through.
⇒ The needle (6) is pushed a little backwards out of the housing.
9. Remove the needle (6).
10. Replace worn out or defective components.

Assembly

11. Push the needle (6) carefully into the housing.
12. Secure needle (6) on the wrench mount in the center of the spray gun with the monkey wrench before twisting.

13. Insert the needle tip (5). Tighten using the installation wrench.
14. Insert and tighten nozzle (2).
Tightening torque: 15Nm
15. Fit air cap (1).
16. Tighten cap nut (1).
17. Push needle spring and bearing (3) onto the needle.
18. Set and thread-in set screw (4).

9.3.2 Replace valve set

Personnel:

- Operator
- + additional qualification explosion protection

Protective equipment:

- Protective workwear
- Protective gloves

Tool:

- M68900005 - Assembly plug
- W02020421 - Tool for sealing ring assembly 9x6
- W02020422 - Tool for O-ring assembly 13x1
- W02020423 - Tool for saddle seal assembly 12.3x9.3
- W02020226 - Assembly tool for sealing rings

Disassembly

1. Disassemble air cap, nozzle and needle
↳ 9.3.1 "Replace needle and nozzle."

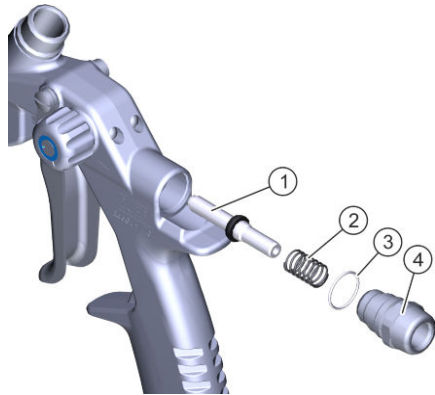

Fig. 16: Disassemble valve seal

2. Thread off bushing (4).
3. Remove compression spring (2).
4. To replace the O-ring (3), lever out the O-ring (3) from the housing using a sharp object (or Dürr tool W02020226).
5. Push trigger lever through.
⇒ The valve pin (1) is pushed a little backwards and out from the housing.
6. Remove valve pin (1).

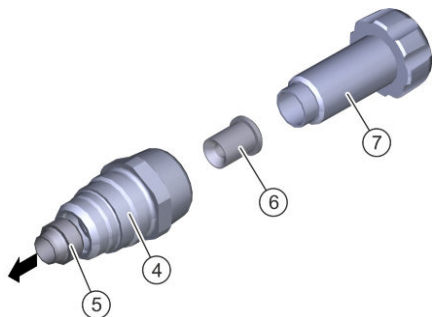

Fig. 17: Disassemble bushing seal

7. Insert the assembly plug (M68900005) (6) in the bushing (4).
8. Screw-in set screw (7) in the bushing (4) using the assembly plug (6).
⇒ The seal (5) is pushed out from the bushing (4).

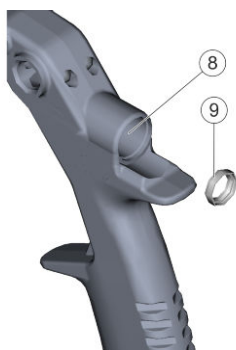

Fig. 18: Disassemble valve seat

9. Lever out the valve seat (9) from the housing opening (8) using a sharp object (or Dürr tool W02020226).

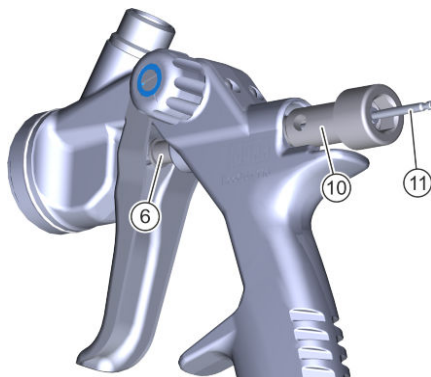

Fig. 19: Disassemble seal

10. Push in assembly plug (6) carefully into the gun housing behind the trigger lever. The contact surface of the assembly plug must point in the direction of the trigger lever.
11. Push in installation wrench (10) carefully into the gun housing from behind.
12. Push in dismantled needle (11) through the installation wrench (10) into the gun housing.
13. Push trigger lever through.
⇒ The seal on the inside is pushed onto the installation wrench (10).
14. Pull out needle (11).

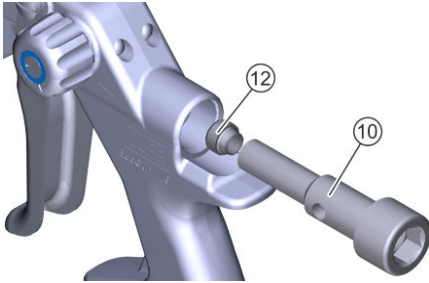



Fig. 20: Disassemble seal

15. Pull out the installation wrench (10) with seal (12).
16. Pull out assembly plug (6).
17. Replace worn out or defective components.

Assembly

18. Spray the seal seat in the housing with cleaner (e.g. Loctite SF 7063). Let cleaner air dry.
19. Lubricate installation wrench (or Dürr tool W02020421) lightly with Syntheso GLEP 1.
20. Thread seal (12) onto installation wrench (or DÜRR tool W02020421).
21. Coat primer (e.g. Loctite 770) thinly on the exterior surface of the seal (12) an the integrated O-ring. Let primer air dry.
22. Coat the exterior surface in the front part of the seal (in front of the O-Ring) with contact adhesive (e.g. Loctite 454). Immediately push the seal with the installation wrench (10) into the housing. Press in seal.
23. Pull out installation wrench (10).

⇒ The seal (12) remains in the housing.

 The contact adhesive must harden for at least an hour before additional assemble steps.

24. Lubricate installation wrench (or Dürr tool W02020421) lightly with Syntheso GLEP 1.

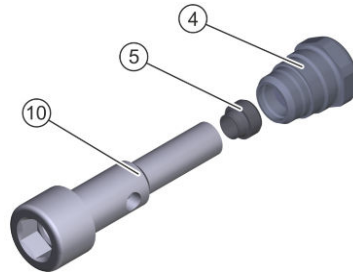

Fig. 21: Assemble the bushing seal

25. Thread seal (5) on the installation wrench (10).
26. Lubricate exterior surface of the seal with Syntheso GLEP 1.
27. Push the installation wrench (10) with seal into the bushing (4). Press in seal. ⇒ Pull out installation wrench (10). Seal (5) remains in the bushing (4).

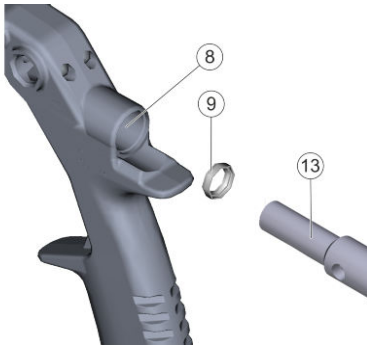

Fig. 22: Assemble valve seat

28. Thread valve seat (9) onto tool W02020423 (13). Insert valve seat with the tool into the housing opening (8).
29. Lightly lubricate valve pin (1) with Syntheso GLEP 1.
30. Insert valve pin (1).
31. Thread O-ring (3) onto Dürr tool W02020422. Press O-ring (3) into the housing using Dürr tool W02020422.
⇒ Pull tool out of the housing. The O-ring remains in the housing.
32. Insert compression spring (2).
33. Screw-in bushing (4) into the housing.
34. Install air cap, nozzle and needle
↪ 9.3.1 "Replace needle and nozzle."

9.3.3 Replace needle gland

Personnel:

- Operator
- + additional qualification explosion protection

Protective equipment:

- Protective workwear
- Protective gloves

Disassembling

1. Remove needle ↪ 9.3.1 "Replace needle and nozzle."

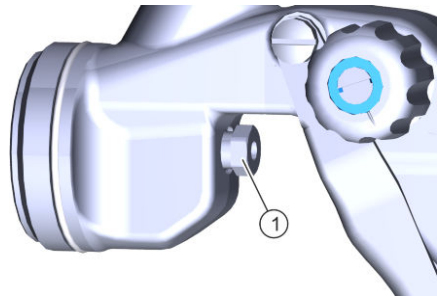

Fig. 23: Disassemble gland bolt

2. Loosen gland bolt (1) and remove it.

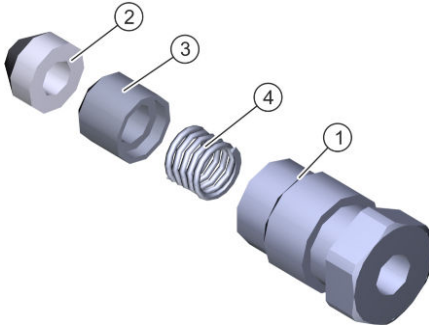



Fig. 24: Disassemble needle packing

3. Remove needle gland (2) with spring guide (3) and gland spring (4).
4. Replace worn out or defective components.

Assembling

5.  See that the alignment of the components to be installed is correct.

Push in needle carefully into the housing, until the needle tip comes out in the area of the trigger.

6. String gland bolt (1).
7. String gland spring (4).
8. String spring guide (3).
9. String needle gland (2).
10. Tighten gland bolt (1) sensitively.



If there are leakages in operation after you replace the needle gland seal, you have to tighten the needle gland seal a little more.

11. Install needle  9.3.1 "Replace needle and nozzle."

10 Disassembly and Disposal

10.1 Safety recommendations



WARNING!

Escaping material and compressed air

Escaping material under pressure can cause serious injuries.

Before carrying out any work:

- Disconnect the system, in which the spray gun is installed, from compressed air and material supply.
- Secure system personalized from being switched on again.
- Depressurize the lines.

10.2 Disassembly

Personnel:

- Operator
- + additional qualification explosion protection

Protective equipment:

- Use ear protection
- Eye protection
- Respiratory protection device
- Protective workwear
- Protective gloves

1. Rinse the spray gun ↪ 6.7 “Purging”.
2. Disconnect the compressed air supply and material feed. Secure against reconnection.
3. Disconnect all lines.

10.3 Disposal



ENVIRONMENT!

Improper waste disposal

Improper waste disposal threatens the environment and prevents re-use and recycling.

- Clean components before their disposal.
- Always dispose of components in accordance with their characteristics. ↪ 11.7 “Materials used”
- Collect leaked out utilities and auxiliaries completely.
- Dispose of work equipment soaked in coating materials or operating substances according to the disposal provisions in force.
- Dispose of utilities and auxiliaries according to the disposal provisions in force.
- In case of doubt, refer to the local disposal authorities.

11 Technical data

11.1 Weight

Detail	Value
Weight (with AL air cap, 1.8-mm nozzle and G3/8" cup connection, without feed cup)	499 g

11.2 Connections

Connection	Nominal width
Material	G3/8"/M16x1.5
Air	G 1/4"

11.3 Operating conditions

Detail	Value
Maximum allowable material temperature when operating with protective gloves	40 °C
Maximum allowable material temperature when operating with heat-resistant protective gloves	60 °C

11.4 Emissions

Detail	Value
Emission sound pressure level L_{pA} , A – according to EN 14462	86 dB
Uncertainty K_{pA}	5dB

Technical data

Detail	Value
Sound power level L_{WA} , A – according to EN14462	99.8 dB
Uncertainty K_{WA}	5dB

11.5 Operating values

Detail	Value
Max. air pressure	4bar
Air pressure, optimum	2 to 3 bar

Compressed air quality

- Purity classes in accordance with ISO 8573-1: 1:4:2
- Limitations for purity class 4 (pressure dew point max.):
 - $\leq -3^{\circ}\text{C}$ at 7bar absolute
 - $\leq +1^{\circ}\text{C}$ at 9bar absolute
 - $\leq +3^{\circ}\text{C}$ at 11bar absolute

11.6 Type plate

The type plate is placed on the housing and features the following details:

- Product designation
- Material number
- Year of manufacture
- Serial number
- EX labeling
- Manufacturer
- CE labeling

11.7 Materials used

Component	Material
Housing	Nickel-plated or anodized aluminum
Compression springs	Stainless steel
Materials in contact with material	Stainless steel, nickel-plated or anodized aluminum POM
Seals in contact with material	PTFE PTFR with 25% coal
Seals without material contact	PE PTFE POM

11.8 Operating and auxiliary materials

Material	Material number
Grease tube Syntheso GLEP 1, 100g (for seals and threads)	W32020010
Loctite 577 (Thread sealant)	W31010005

11.9 Material specification

Suitable Material:

- Ignitable coating materials
- Non-flammable coating materials



Do not use halogen - hydrocarbon based material.

12 Spare parts, tools and accessories

12.1 Spare parts

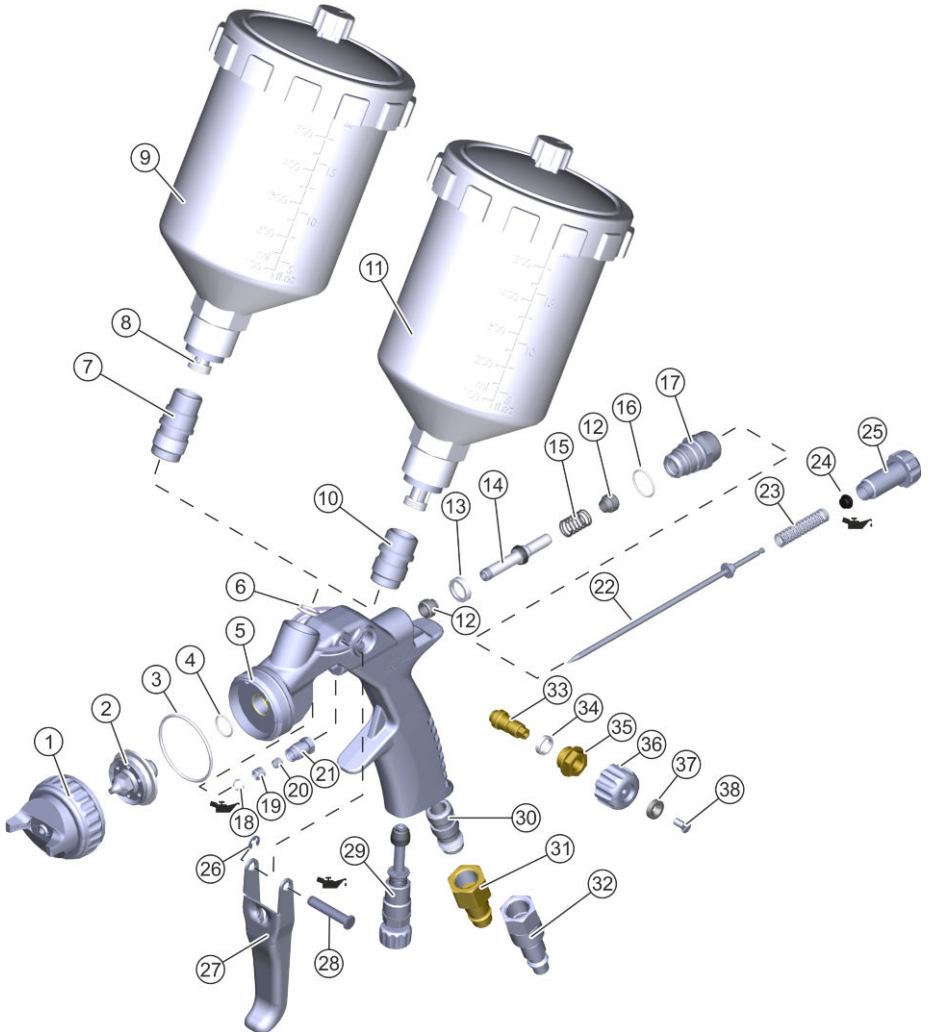

Fig. 25: Exploded view

Item	Denomination	Quantity	Material no.
1	Air cap	1	↳ "Overview - Air caps and nozzles"
2	Nozzle with seal	1	
-	Seal	1	M08190077
3	O-ring 33.3x1.6	1	M08030814
4	O-Ring 10x1	1	M08030866
5	Housing	1	
6	O-Ring 8.4x1.78	1	N36960133
7	Material connection G3/8"	1	
8	Filter	1	M13010029
9	Feed cup plastic G3/8" with filter, 600ml	1	N08010034
	Feed cup aluminum G3/8", 750ml	1	N08010035
	Feed cup plastic G3/8" without filter, 125ml	1	N08010031
10	Material connection M16x1.5	1	
11	Feed cup plastic M16x1,5 with filter, 600ml	1	N08010040
12	Seal 9x6 PE-UHMW/FKM	2	N36960306
13	Valve seat 12.3x9.3	1	
14	Valve pin complete with seal	1	
15	Valve pin spring	1	
16	O-ring 13x1	1	
17	Bushing	1	M05010190
18	Needle gland	1	M08280242
19	Spring guide	1	
20	Gland spring	1	
21	Gland bolt	1	
22	Needle	1	↳ "Overview - Air caps and nozzles"
23	Needle spring	1	N36960107
24	Bearing	1	
25	Set screw	1	
26	Safety washer	1	Trigger set N36960043

Item	Denomination	Quantity	Material no.
27	Trigger	1	
28	Bolt	1	
29	Air flow control with seal	1	M21200006
-	Seal	1	M08280057
30	Air connection G1/4"	1	M01010213
31	Push-on nipple (stable) for quick action coupling	1	↳ 12.3 "Accessories"
32	Push-on nipple (turns and swivels) for quick action coupling	1	
33	Control screw	1	
34	Seal	1	M08280058
35	Bushing	1	
36	Rotary control	1	
37	Paint ring (black)	1	
38	Screw	1	

Overview - Air caps and nozzles



Nozzle sets consist of needle and nozzle with or without air cap.

Nozzle sets with AL air cap

Nozzle diameter	Nozzle description	Needle description	Item no.	Material no.
1.0mm	10 U	U1	1, 2, 22	M09800148
1.2mm	12 U	U1		M09800149
1.3mm	13 U	U2		M09800150
1.4mm	14 U	U2		M09800151
1.6 mm	16 U	U3		M09800152
1.8 mm	18 U	U3		M09800153
2.0mm	20 U	U4		M09800154
2.2mm	22 U	U4		M09800155
1,4 mm*	14 UT	U2		M09800156

Nozzle diameter	Nozzle description	Needle description	Item no.	Material no.
1.8 mm*	18 UT	U3		M09800157
2.2 mm*	22 UT	U4		M09800158

* - Nozzle and needle hardened

Nozzle sets with EL air cap				
Nozzle diameter	Nozzle description	Needle description	Item no.	Material no.
2.8mm	28 U	U6	1, 2, 22	M09800165

Nozzle sets with GL air cap				
Nozzle diameter	Nozzle description	Needle description	Item no.	Material no.
4.0mm	40 U	U7	1, 2, 22	M09800166

Nozzle sets without air cap					
Nozzle diameter	Nozzle description	Needle description	suitable air cap	Item no.	Material no.
1.0mm	10 U	U 1	AL	2, 22	M09800246
1.2mm	12 U	U 1	AL		M09800247
1.3mm	13 U	U 2	AL		M09800248
1.4mm	14 U	U 2	AL		M09800249
1.6 mm	16 U	U 3	AL		M09800251
1.8 mm	18 U	U 3	AL		M09800252
2.0mm	20 U	U 4	AL		M09800254
2.2mm	22 U	U 4	AL		M09800255
1,4 mm*	14 UT	U 2	AL		M09800250
1.8 mm*	18 UT	U 3	AL		M09800253
2.2 mm*	22 UT	U 4	AL		M09800256
2.8mm	28 U	U 6	EL		M09800257
4.0mm	40 U	U 7	GL		M09800258

* - Nozzle and needle hardened

Air caps		
Air cap type	Item no.	Material no.
AL	1	M35030162
EL		M35030163
GL		M35030164

Repair set needle seal N36960023

Description	Item no.	Quantity
Needle gland	18	1
Spring guide	19	1
Gland spring	20	1
Gland bolt	21	1

Seal set nozzle and air cap N36960109

Description	Item no.	Quantity
O-ring 33.3x1.6	3	1
O-Ring 10x1	4	1
O-Ring 8.4x1.78	6	1

Flat Jet Control Set (Blue Color Ring) N36960111

Description	Item no.	Quantity
Control screw	33	1
Seal	34	1
Bushing	35	1
Rotary control	36	1
Paint ring (blue)	37	1
Screw	38	1

Material connection set M 16 x 1.5 N36960137

Description	Item no.	Quantity
O-Ring 8.4x1.78	6	1
Material connection M16x1.5	10	1

12.2 Tools

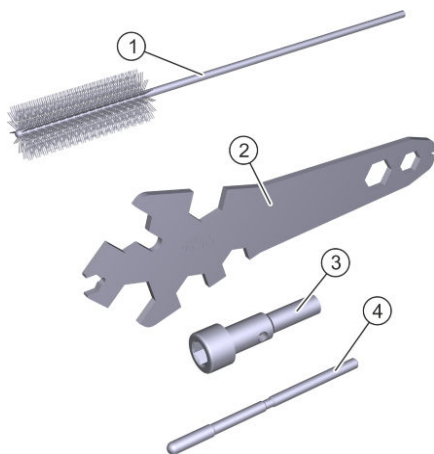

Fig. 26: Tools

Tool kit N36960045

Description	Item no.	Quantity
Cleaning brush	1	1
Monkey wrench	2	1
Installation wrench	3	1
Assembly rod	4	1

Additional tools

The following tools are not included in the scope of delivery.

Description	Material no.
Tool sealing ring assembly/disassembly	W02020226
Tool for O-ring assembly 33.3x1.6	W02020420
Tool for sealing ring assembly 9x6	W02020421
Tool for O-ring assembly 13x1	W02020422
Tool for saddle seal assembly 12.3x9.3	W02020423

Description	Material no.
Tool for O-ring assembly 9.3x1/10x1	W02020424
Assembly plug	M68900005

12.3 Accessories







An overview of the accessory is available at Dürr webshop or upon request, ↗ "Hotline and Contact".

Push-on nipple for quick-action coupling

Description	Item no.	Material no.
Push-on nipple for quick-action coupling, fixed D7,2 d10/12 (EU)	31	M01010185
Push-on nipple for quick-action coupling, pivoted and rotatable D7.2 d10/12 (EU)	32	M01300006
Color ring set (red, yellow, green, blue, black)	37	N36960088
Cleaning set 17 parts	-	N36960037
Cleaning set (21 parts)	-	N36960038
Regulator, compressed air 0-7bar 1/4"out-1/4"in	-	N26050282
Connection air G1/4" 8x6 kink protection	-	M01010214
Quick change coupling for air G1/4" - external threads	-	N40030046
DIN cup 4mm	-	N08010047
DIN cup 2 mm	-	N08010053
DIN cup 6 mm	-	N08010054

Extensions overview

Extension	Spray pattern	Spray jet shape
NP		Round forward
NS		Round, deviating 20° from the extension axis
LPS		Round forward
		360 degree round jet

Description	Length*	External diameter	Weight	Nozzle diameter	Material no.
Extension NP 250-10	250mm	10mm	320g	1.2mm	M19140016
Extension NS 250-10					M19140017
Extension LPS 300	300 mm	18mm	230g	2.2mm	M19140010

* - Other lengths are available upon request, ↗ "Hotline and Contact".

Extension NP 250-10 (M19140016) and NS 250-10 (M19140017)

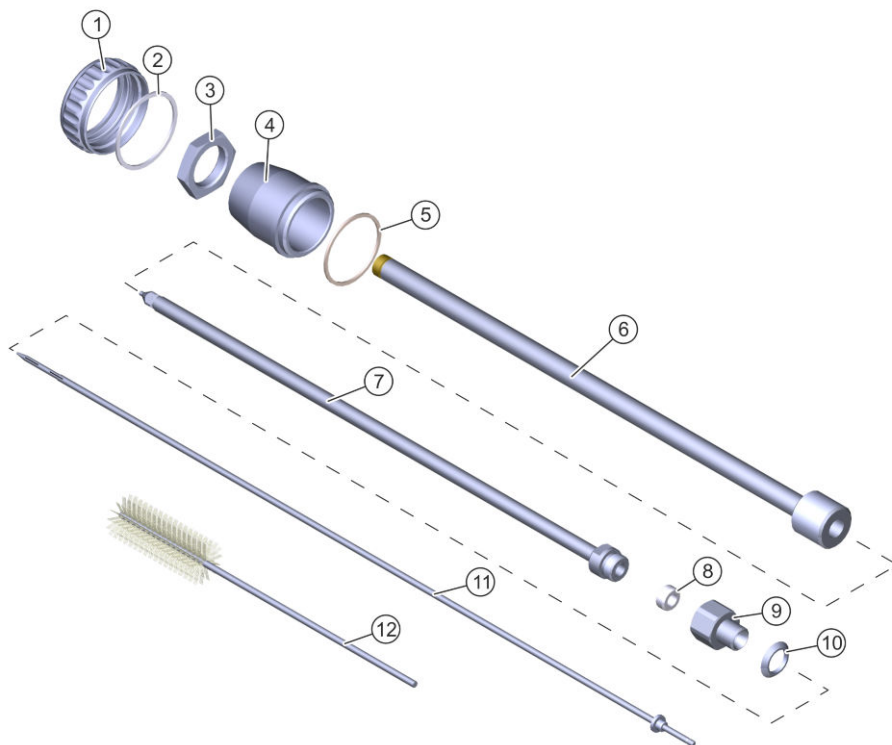

Fig. 27: Extension NP/NS

Item	Description	Material no.
1	Cap nut	M30010334
2	Sealing ring $\varnothing 36.5 \times \varnothing 32.7 \times 1$	see sets
3	Locknut	M30030113
4	Housing	M19140032
5	Seal $\varnothing 33.7 \times \varnothing 30.6 \times 1$	see sets
6	Extension pipe NP 10-250	M19140035

Item	Description	Material no.
	Extension pipe NS 10-250	M19140038
7	Internal pipe with nozzle	see sets
8	Seal	
9	Screw bit	M58170027
10	Ball sealer	see sets
11	Needle	
12	Cleaning brush	↳ 12.2 "Tools"



Assembly instructions

- Disassemble air cap, nozzle and needle ↳ 9.3.1 "Replace needle and nozzle."
- Thread the ball sealer (10).
- Turn in and tighten screw bit (9) with pre-assembled seal (8) and pre-assembled inner pipe with nozzle (7) into the gun.
- Push housing (4) with seal (5), pre-assembled outer pipe (6) and locknut (3) on to the inner pipe (7).
- Fit and tighten cap nut (1) with sealing ring (2).
- Set outer pipe (6).
 - The outer pipe (6) is adjustable and allows varying setting positions of the air cap on the nozzle. The farther the nozzle projects over the front side of the air cap, the wider is the spray jet. Projection of the nozzle above the air cap should be minimal.
- Tighten the locknut (3).
- Carefully push the needle (11) from behind into the gun housing.
- Insert needle spring, bearing and set screw again ↳ 9.3.1 "Replace needle and nozzle."
- Purge the gun with solvent ↳ 6.7 "Purging".
- Set the material quantity ↳ 5 "Commissioning".

Nozzle set NP/NS 250-10 (M09800434)

Description	Item no.	Quantity
Internal pipe with nozzle	7	1
Seal	8	1
Needle	11	1

Seal set for Extension NP/NS (N36960181)

Description	Item no.	Quantity
Sealing ring \varnothing 36.5x \varnothing 32.7x1	2	1
Seal \varnothing 33.7x \varnothing 30.6x1	5	1
Seal	8	1
Ball sealer	10	1

Extension LPS 300 (M19140010)

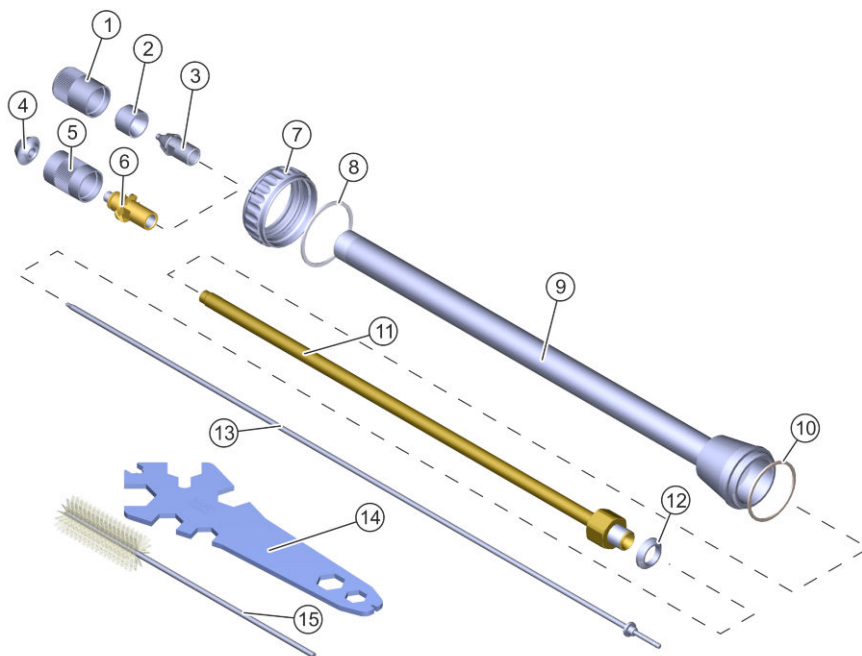

Fig. 28: Extension LPS



The accessories set contains parts that are not suitable for **EcoGun 116** with feed cup (see table). A minimum material pressure is needed.

Item	Description	Material no.
1	Cap nut	see sets
2	Air cap	
3	Nozzle Ø 2.2mm	
4	Baffle (not for EcoGun 116 with feed cup)	
5	Air cap (not for EcoGun 116 with feed cup)	
6	Insert (not for EcoGun 116 with feed cup)	
7	Cap nut	M30010334
8	Sealing ring Ø 36.5xØ 32.7x1	see sets
9	Outer tube	M19140044
10	Seal Ø 33.7xØ 30.6x1	see sets
11	Internal pipe 300mm	M34010602
12	Ball sealer	see sets
13	Needle	
14	Monkey wrench	↳ 12.2 "Tools"
15	Cleaning brush	



Assembly instructions

- Disassemble air cap, nozzle and needle ↳ 9.3.1 "Replace needle and nozzle."
- Thread the ball sealer (12). Tighten the gun with the inner pipe (11).
- Push up external pipe (9) with seal (10).
- Thread on and tighten cap nut (7) with sealing ring (8).
- Insert and tighten nozzle (3).
- Insert air cap (2). Tighten with cap nut (1).
- Carefully push the needle (13) from behind into the gun housing.
- Insert needle spring, bearing and set screw again ↳ 9.3.1 "Replace needle and nozzle."
- Purge the gun with solvent ↳ 6.7 "Purging".
- Set the material quantity ↳ 5 "Commissioning".

Nozzle set C for LPS 300 (M09800444)

Description	Item no.	Quantity
Baffle	4	1
Air cap	5	1
Insert	6	1
Needle	13	1

Nozzle set R for LPS 300 (M09800438)

Description	Item no.	Quantity
Cap nut	1	1
Air cap	2	1
Nozzle	3	1
Needle	13	1

Seal set for extension LPS (N36960183)

Description	Item no.	Quantity
Sealing ring Ø 36.5xØ 32.7x1	8	1
Seal Ø 33.7xØ 30.6x1	10	1
Ball sealer	12	1

12.4 Order



WARNING!

Unsuitable spare parts in explosive areas

Spare parts not compliant with the specifications on explosion protection can cause explosions in an explosive atmosphere. Serious injury and death could be the consequence.

- Use exclusively original spare parts.



WARNING!

Unsuitable spare parts

Spare parts of third-party suppliers may possibly not be able to hold the loads. Serious injury and death could be the consequence.

- Use exclusively original spare parts.

Ordering spare parts, tools and accessories as well as information on products that are listed without order number, ↗ “Hotline and Contact”.



LEADING IN
PRODUCTION
EFFICIENCY

 Dürr Systems AG
Application Technology
Carl-Benz-Str. 34
74321 Bietigheim-Bissingen
Germany

 Phone +49 7142 78-0

 www.durr.com

Translation of the original operation manual
MSG00017EN, V04

The distribution and reproduction of this document as well as the use and communication of its contents are not permitted without express written approval. Violations will be liable for damages. All rights reserved in the event of the grant of a patent or utility model.

© Dürr Systems AG 2017